

MAXIM

MAX3744/MAX3745 Evaluation Kit

General Description

The MAX3744/MAX3745 evaluation kit (EV kit) allows complete evaluation of both versions of 2.7Gbps transimpedance amplifiers.

The EV kit includes a circuit that emulates the high speed, zero-to-peak current input signal that would be produced by a photodiode. The kit also includes a calibration circuit that allows accurate bandwidth measurement.

The MAX3744/MAX3745 EV kit is fully assembled and tested.

Features

- ◆ Fully Assembled and Tested
- ◆ Includes Photodiode Emulation Circuit
- ◆ Calibration Circuit for Accurate Bandwidth Measurement

Ordering Information

PART	TEMP RANGE	IC-PACKAGE
MAX3744EVKIT	-40°C to +85°C	Die
MAX3745EVKIT	-40°C to +85°C	Die

Electrical Evaluation Component List

DESIGNATION	QTY	DESCRIPTION
C3, C5, C6	3	0.01 μ F \pm 10% ceramic capacitors (0201)
C4, C7, C8, C10, C11	5	0.1 μ F \pm 10% ceramic capacitors (0402)
C2	1	10 μ F \pm 10% 10V min ceramic capacitor
C1	1	33 μ F \pm 5% 10V min tantalum capacitor
R3, R4, R11, R12	4	499 Ω \pm 1% resistor (0402)
R5, R8	2	4.99k Ω \pm 1% resistor (0402)
R6, R7	2	53.6 Ω \pm 1% resistor (0402)
R9, R10	2	49.9 Ω \pm 1% resistor (0402) MAX3744 EV board
		Not installed MAX3745 EV board
R13, R14	2	24.9 Ω \pm 1% resistor (0402) MAX3744 EV board
		0 Ω shunt resistor (0402) MAX3745 EV board
R15, R16	2	10k Ω \pm 1% resistor (0402)

DESIGNATION	QTY	DESCRIPTION
L1	1	56nH inductor Coilcraft 1008CS-560XKBC
JU1	1	2-pin header, 0.1in centers
J3-J7	5	SMA connectors, round, Johnson 142-0701-801
TP1-TP4	4	Test Points
U1	1	MAX3744E/D MAX3744 EV board
		MAX3745E/D MAX3745 EV board
Outside Vendor Supply	0	1mil Au wire (8 bonds)
Outside Vendor Supply	0	Epoxy, Ablefilm 84-1 LMI
None	1	Shunt
None	1	MAX3744 EV board
		MAX3745 EV board
None	1	MAX3744/MAX3745 Data Sheet

Evaluates: MAX3744/MAX3745

For pricing, delivery, and ordering information, please contact Maxim/Dallas Direct! at 1-888-629-4642, or visit Maxim's website at www.maxim-ic.com.

MAX3744/MAX3745 Evaluation Kit

Component Suppliers

SUPPLIER	PHONE	FAX
AVX	803-946-0690	803-626-3123
Coilcraft	847-639-6400	847-639-1469
Murata	814-237-1431	814-238-0490

Note: Please indicate that you are using the MAX3744/MAX3745 when contacting these component suppliers.

Quick Start

- 1) Connect a signal source to IN at J3. Set the signal amplitude to 100mVp-p (this may require some attenuation between the source and the MAX3744/MAX3745 EV kit.) The signal should have a data rate of 2.5Gbps.
- 2) Connect OUT+ and OUT- to the 50O inputs of a high-speed oscilloscope at J6 and J7.
- 3) Remove the shunt from jumper JU1.
- 4) Connect a +3.3V supply to the VCC terminal and ground to the GND terminal.
- 5) The differential signal at the oscilloscope should be greater than 280mVp-p (140mVp-p on MAX3744 EV Kit).

Detailed Description

The MAX3744/MAX3745 EV kit allows characterisation without a photodiode. The kit is designed to emulate a DC-coupled photodiode input. Diode currents may have 6uA_{pp} to 2mA_{pp} AC-current with a DC component from 10uA to 1mA. The high-speed current source of the photodiode is emulated on the EV kit using separate AC and DC paths. The AC signal is supplied from a standard 50O lab source that delivers power to an on board termination resistor. A current is then generated from the voltage signal by a resistor with low stray capacitance. The effect of the DC photodiode current may be emulated by a current source at TP1. An isolation resistor prevents the DC source from loading the AC path.

The values of the series resistive element, R3 and R4, have been carefully selected so that the bandwidth of

the transimpedance amplifier is not altered. Surface-mount resistors have parasitic capacitance that may reduce their impedance at frequencies above 1GHz.

Photodiode Emulation

The following procedure can be used to emulate the high-speed current signal generated by a photodiode:

- 1) Select the desired optical power (P_{AVE} , dBm) and extinction ratio (r_e).
- 2) Calculate the average current (I_{AVE} , A). Set the DC current at TP1 to I_{AVE} .

$$I_{AVE} = \frac{10^{(P_{AVE}/10)}}{1000} \cdot \rho$$

(ρ = photodiode responsivity in A/W)

- 3) Calculate the AC signal current and adjust the signal generator to obtain it.

$$I_{AC} = 2 \cdot I_{AVE} \cdot \frac{r_e - 1}{r_e + 1}$$

For example: To emulate a photodiode with an average power of -16dBm and an extinction ratio of 10;

- 1) -16dBm optical power will produce 25uA of average input current (assume photodiode responsivity of 1A/W). Set the DC current input to 25uA at TP1.
- 2) The signal amplitude is $2 I_{AVE} (r_e - 1) / (r_e + 1) = 41\mu A$. To generate this current through the 1000O input resistors, set the signal source to produce an output level of

$$41\mu A \cdot 1000 O = 41mVp-p.$$

Noise Measurement

Remove R3 and R4 before attempting noise measurements to minimize input capacitance. With R3 and R4 removed the total capacitance at the IN pin is approximately 0.85pF.

RSSI (MAX3744)

The Average Power at the MAX3744 input is indicated by the common mode output measured at TP2 and TP3. Refer to the MAX3744 data sheet for details.

Adjustments and Control Descriptions

COMPONENT	NAME	FUNCTION
JU1	OFFSET CORRECTION	Instal JU1 to disable offset correction.
TP1	DC CURRENT INPUT	Apply DC current for photodiode simulation.
TP2, TP3	OUTPUT COMMON MODE	MAX3744 RSSI Signal

MAX3744/MAX3745 Evaluation Kit

Evaluates: MAX3744/MAX3745

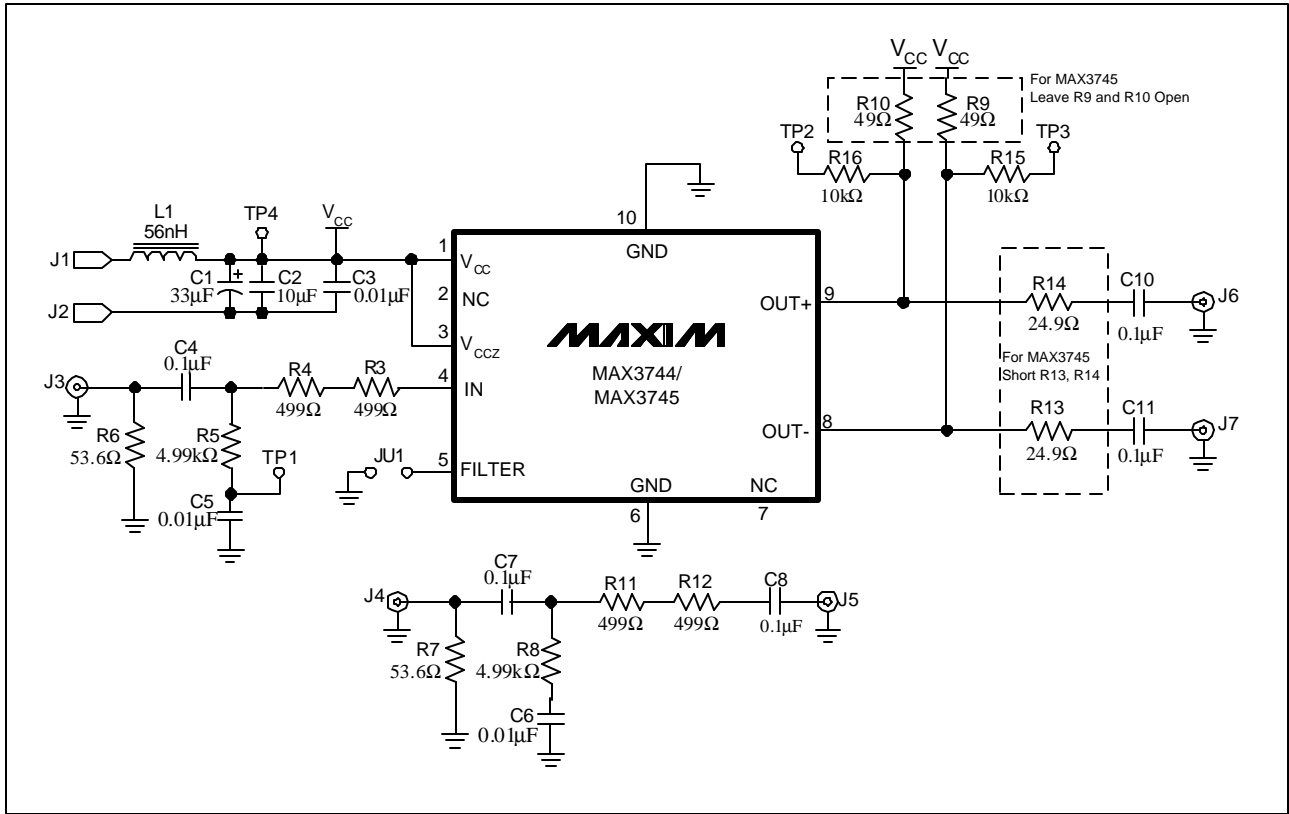

Figure 1. MAX3744/MAX3745 EV Kit Schematic



Figure 2. MAX3744/MAX3745 EV Kit PC Component Placement Guide—Component Side

MAX3744/MAX3745 Evaluation Kit

Evaluates: MAX3744/MAX3745

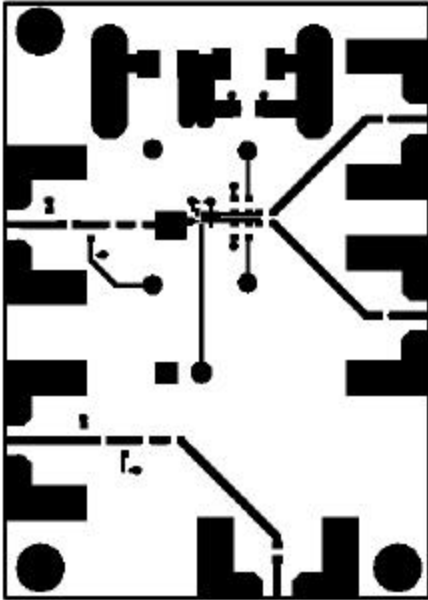

Figure 3. MAX3744/MAX3745 EV Kit
PC Board Layout—Component Side

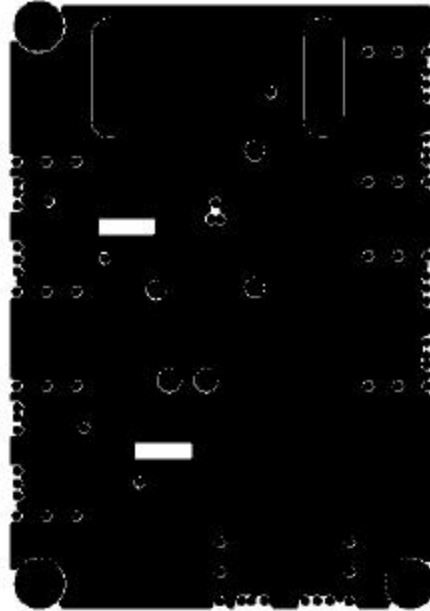

Figure 5. MAX3744/MAX3745 EV Kit
PC Board Layout—Power Plane

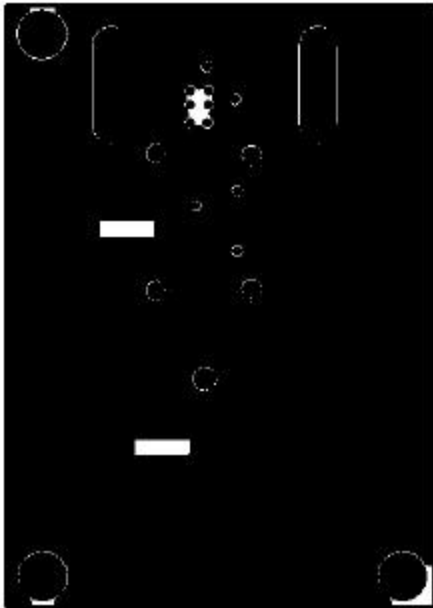

Figure 4. MAX3744/MAX3745 EV Kit
PC Board Layout—Ground Plane

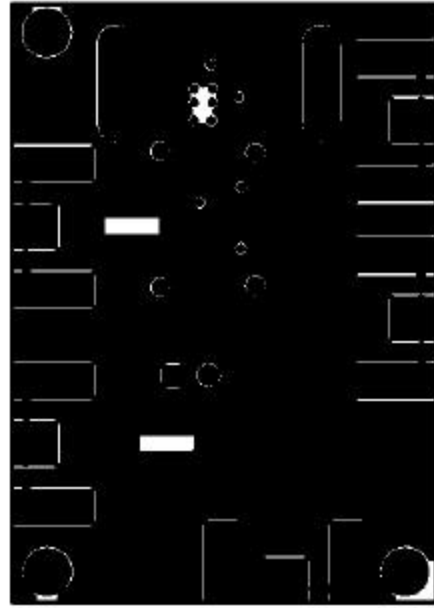

Figure 6. MAX3744/MAX3745 EV Kit
PC Board Layout—Solder Side

Maxim cannot assume responsibility for use of any circuitry other than circuitry entirely embodied in a Maxim product. No circuit patent licenses are implied. Maxim reserves the right to change the circuitry and specifications without notice at any time.

Maxim Integrated Products, 120 San Gabriel Drive, Sunnyvale, CA 94086 408-737-7600

4